

**Do-It-Yourself Household OSCR Junior:**

With three, 16"x24", 10 gallon Rubbermaid®, Keepers™, Rough Totes and Oregon Soil Corporation technology, you can make a flow through worm bin in an afternoon.

With one pound of red worms you can cover 1/2 pound of food waste to a valuable soil amendment.

Alternating layers of high carbon bedding material and food waste are stabilized as red worm castings.

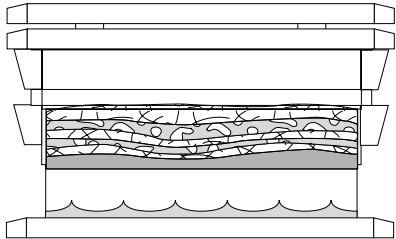

Base provides ventilation and means to capture nutrient tea leachate.

Reactor bin, top view

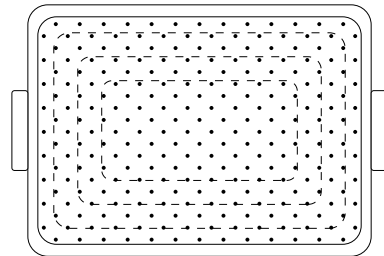

Reactor bin, side view

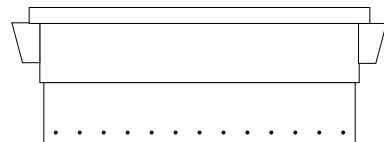

1/4 inch holes  
 1 1/2 inch centers across horizontal rows  
 1/2 inch vertical offset between rows  
 3/4 inch offset alternating between rows

When first reactor bin is near full, place second reactor bin on top and continue with alternating layers of bedding and food waste.

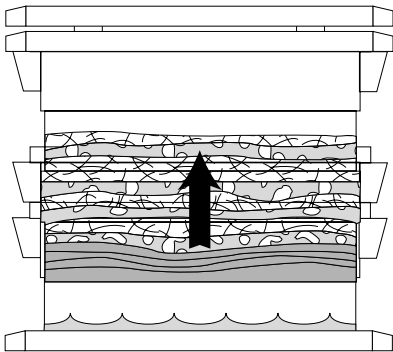

Red worms will travel up through holes into upper reactor chamber as food waste is converted to nutrient rich castings.

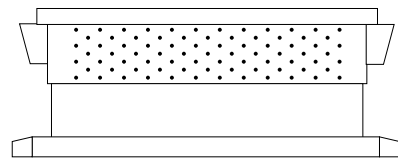

1/4 inch ventilation holes  
 1 1/2 inch centers across horizontal rows  
 1/2 inch vertical offset between rows  
 3/4 inch offset alternating between rows

When top reactor bin is near full, remove lower reactor bin, harvest castings, place decomposing waste and remaining red worms in other bin, place empty bin on top and continue with alternating layers of bedding and food waste.

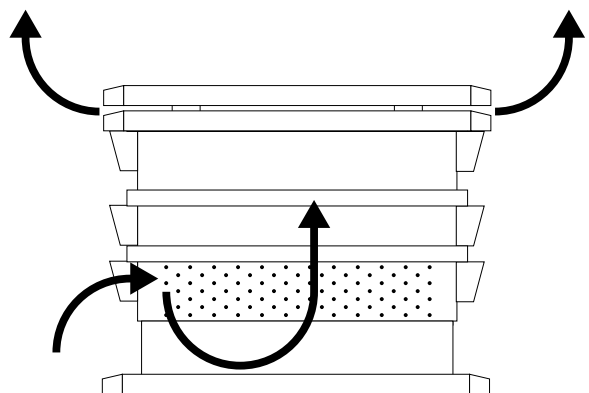
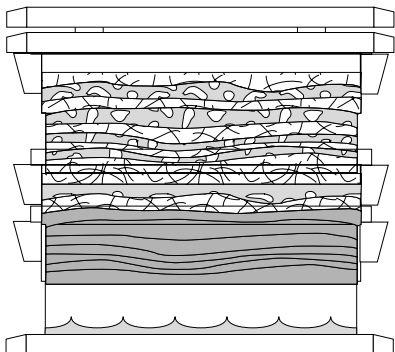

Cool air enters through ventilation holes in base, flows up through compost and is expelled with excess heat and moisture through vented cover.

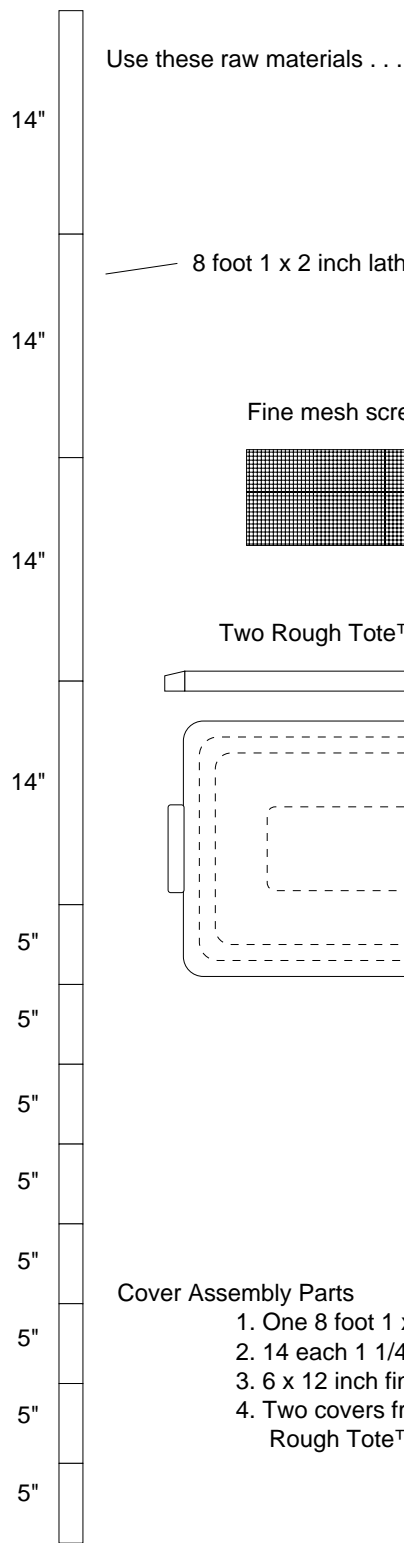

- Cover Assembly Parts**
- 1. One 8 foot 1 x 2 lath
  - 2. 14 each 1 1/4 inch wood screws
  - 3. 6 x 12 inch fine mesh screen
  - 4. Two covers from Rubbermaid® Rough Tote™ storage containers

... to make these parts ...

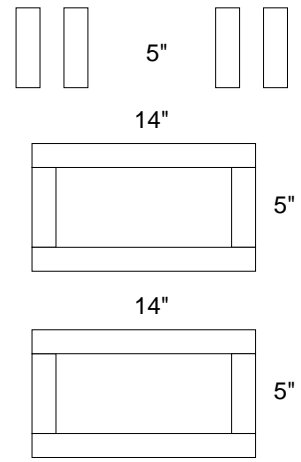

... into a vented worm bin cover.

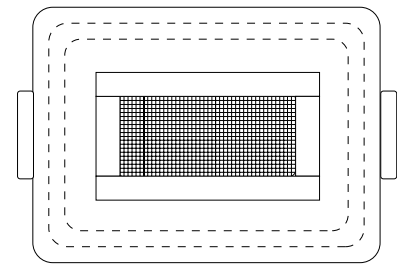

Bottom view.

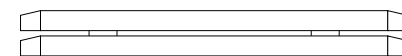

Side view.

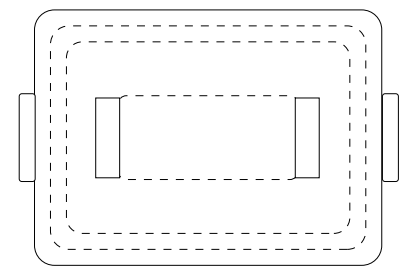

Top view.

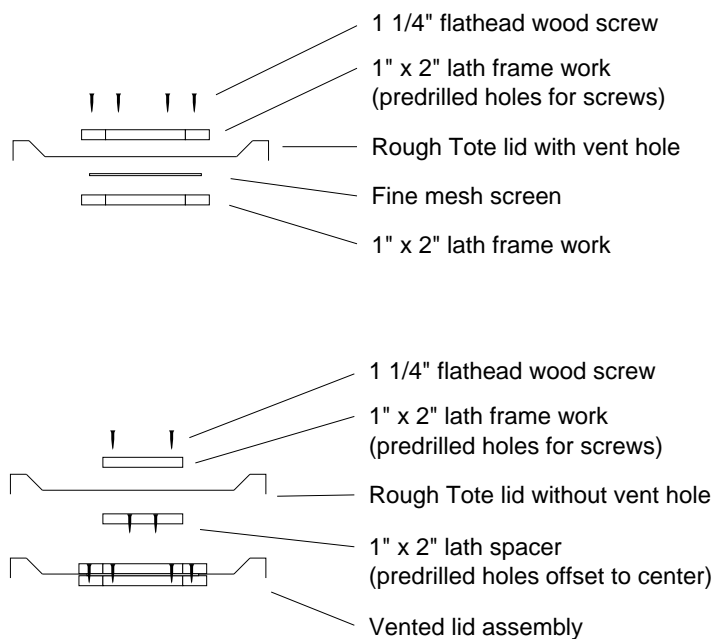

Fully Assembled Cover  
view from narrow end.

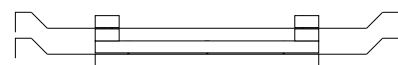

Fully Assembled Cover  
view from long side.